

FS1353/12 shown  
with Re-inforcing Tube



INSTALLATION, OPERATING  
& MAINTENANCE MANUAL

# ATEX GROUP 1 FLOAT SWITCHES

TYPE: FS1353

# Contents

---

1. Safety Instructions .....	1
2. Functional Description .....	2
3. Area of Application .....	3
4. Installation .....	4
5. Electrical Connections .....	6
6. Commissioning / Functional Testing .....	10
7. Maintenance .....	11
8. Technical Data .....	12
9. EC Declaration .....	13

**WARNING:**

*Failure to comply with the instructions described within this manual can lead to malfunction or damage to the switch and if the switch is incorrectly installed the ATEX certification may be void.*

# 1. Safety Instructions

---

Read these instructions before installing the ATEX Group I Horizontal float switch and placing it into operational service.

These instructions are intended for the personnel responsible for the installation and commissioning of the float switch.

Comply with the relevant safety regulations when using the equipment.

Do not install the float switch in the immediate vicinity of any strong electromagnetic fields (recommended min distance >1 meter).

Do not subject the float switch to heavy mechanical loads.

## 2. Functional Description

AMS magnetic float switches are ideal for high and low liquid level alarm, and pump control duties. These Liquids should not contain heavy soiling or coarse suspended matter and must not show a tendency to crystallize when drying out. If the liquids that the float switch is being used to measure do have conditions as listed above then routine maintenance should be carried out to ensure the float has free movement on the guide tube.

The ATEX Group I float switch is designed to open or close a circuit ("switch") as a changing liquid level within a vessel passes the level of the float (the Switch Point).

When the process liquid level is below the Switch Point, the contacts are either open circuit (NO) or closed circuit (NC) depending on the switch configuration as determined by the customer, when the liquid level raises the float will become buoyant and as the liquid level increases passed the switch point the contacts will change over.

The floats have an in- built magnetic which operates the reed switch contact through the wall of the guide tube. Thus the switching operation is without direct contact to the liquid, free of wear and tear, and does not require any power supply.

Benefits of using AMS Magnetic Float Switch Technology

Benefits of using AMS Magnetic Float Switch Technology

- i) Over 40 years of experience – a proven design (Ex Alan Cobham)
- ii) Simple, reliable, and cost effective level measurement technology
- iii) Tough, rugged design for long life in aggressive environments
- iv) Operates in almost any liquid at high pressures and temperatures
- v) Measurement is unaffected by changes in process temperature, dielectric, or the presence of vapours

## 3. Areas of Application



### 3.1 FS1353/- Flameproof ATEX Group I Float Switches

An approval has been issued for the ATEX Group I float switches for use as explosionprotected equipment within the scope of application defined by EU Guideline 94/9/EC ATEX in hazardous areas.

They comply with the specifications concerning equipment and protective systems intended for use in potentially explosive atmospheres.

**THE TECHNICAL DATA IN THIS OPERATING INSTRUCTION MUST BE COMPLIED WITH.**

FS1353/- ATEX Group I Float Switches carry the following Brass ATEX Certification plate:

⊕ AM SENSORS Ltd	FLAMEPROOF SWITCH	⊕
+44 (0) 1278 444650	www.amsensors.com	
Serial.No:	 I M2 Exd I Gb	
Year of Manuf:	 ATEX Certificate no:	
Max.rating:	ITS 14 ATEX 17988	⊕
⊕ Max. liquid temp.150°C	0359	

# 4. Installation

## 4.1 Removal of transport packaging

Remove the float switch carefully from the transport packaging; never forcibly remove the float switch from the packaging.

Always handle the float switch by the switch body, gently supporting the float switch guide tube.

Do not lift the float switch up by the guide tube as this can cause the tube to bend and invalidate any warranty.

Make sure all packaging components have been removed and that the float moves freely on the guide tube.

## 4.2 Installation

The ATEX Group I float switches types FS1353/- are designed to be solely installed in the Vertical position, do not attempt to install this switch design in the horizontal position as the float will not operate the reed switch.

Prior to installing the float switches confirm that the vessel has the correct mounting arrangement for the float switch. The standard mounting arrangement is indicated in Fig 1, with adaptor flanges and screwed process connections options available.

For ease of any future maintenance and removal of the float switches with the standard mounting option, we recommend that that 4 off M14 studs are used installed on a PCD of  $\varnothing 98.4\text{mm}$ .

Insert the float switch and gasket provided through the mounting hole into the vessel; handle the float switch by the float switch body supporting the guide tube as you insert the switch into the vessel.

Assemble the float switch to the vessel using suitable bolts and washers; tighten the float switch mounting nuts to the specific torque rating for the studs and bolts.

# Installation

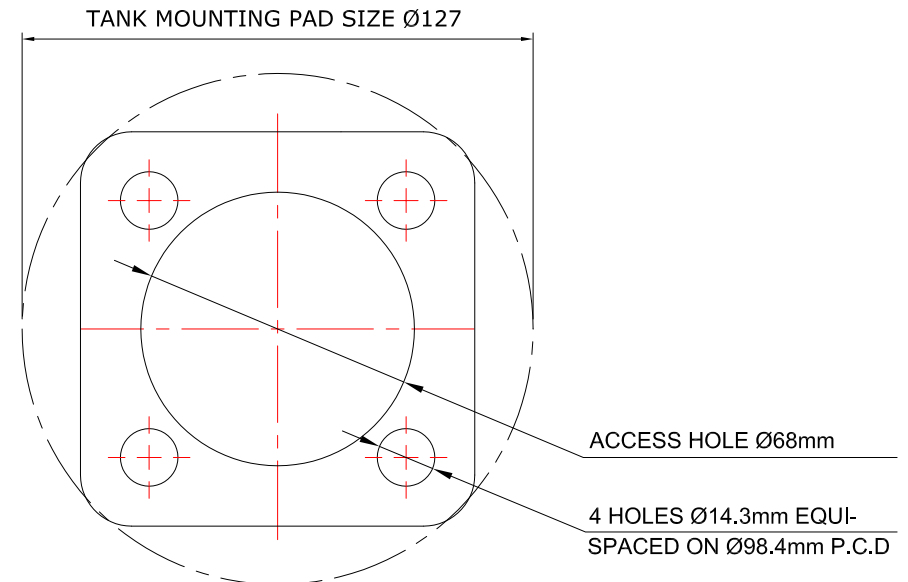
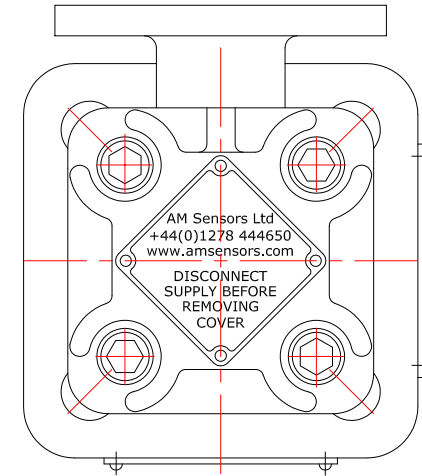

# 5. Electrical Connections

**WARNING:**

*It is essential that the electrical supply to the switch does not exceed the electrical rating of the reed switch and that loads in excess of the maximum reed switch operation are not applied.*

*Ensure the switch is not operated outside its designated temperature range (see label).*

## 5.1 Installing the Cable Gland

If ordered with the switch, install the cable gland flange FS4825 to the ATEX Group I float switch using the M8 x 35mm Bolts, Nuts and washer (supplied with the flange), ensuring that a suitable gasket is installed between the flange faces (not supplied) as shown below.

The cable gland flange FS4825 is designed to take a M25 x 1.5 ATEX rated cable gland, install the cable gland onto the cable gland flange FS4825, ensuring that the manufactures instructions are strictly followed.

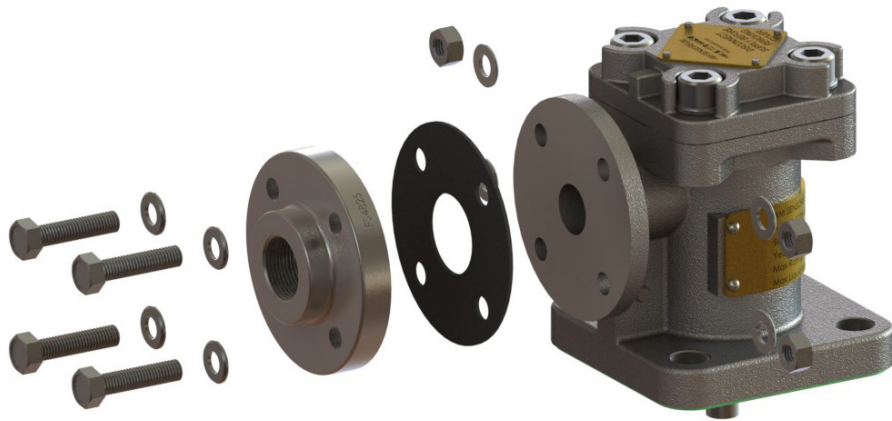

# Electrical Connections

## 5.2 Switch terminal Access

Undo the 4 off M10 socket headed screws and spring washers (Item 1), and while holding the float switch body, carefully lift the lid (Item 2) in an linear direction (gently rotating clockwise and anti-clockwise aids removal of the lid).

Remove the terminals and terminal base (Item 3) in an upwards direction, being careful not to put any strain on the switch wiring.

Once the switches have been terminated to the system, gently insert the terminals and terminal base (Item 3) back into the float switch body; replace the lid (Item 2) onto the body making sure that the O-ring is not trapped.

Replace and tighten the 4 off M10 socket headed screws (Item 1), to no greater than 10 Lbs. torque.

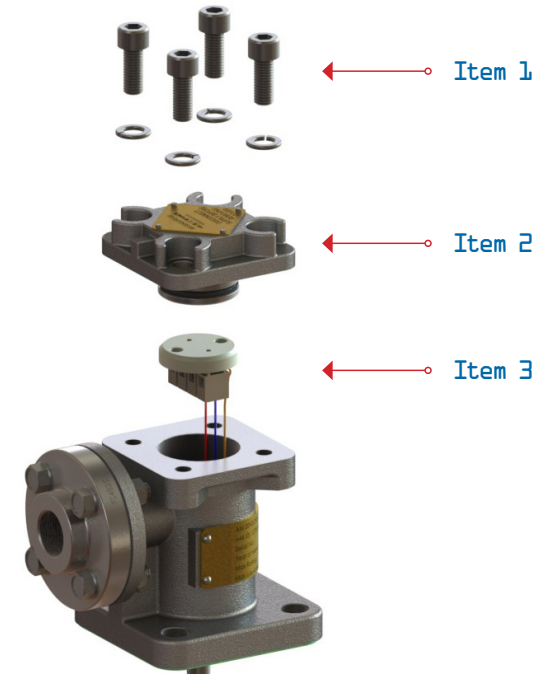

# Electrical Connections

## 5.3 Switch Wiring Configuration

Single pole / double throw switches (options) are terminated using 3 wires; these wires have the following colours and configuration:

Common Wire	Red Wire
Normal Closed Contact	Blue Wire
Normally Open Contact	Orange Wire

The switch wires are terminated to a four way terminal block in the following configuration:

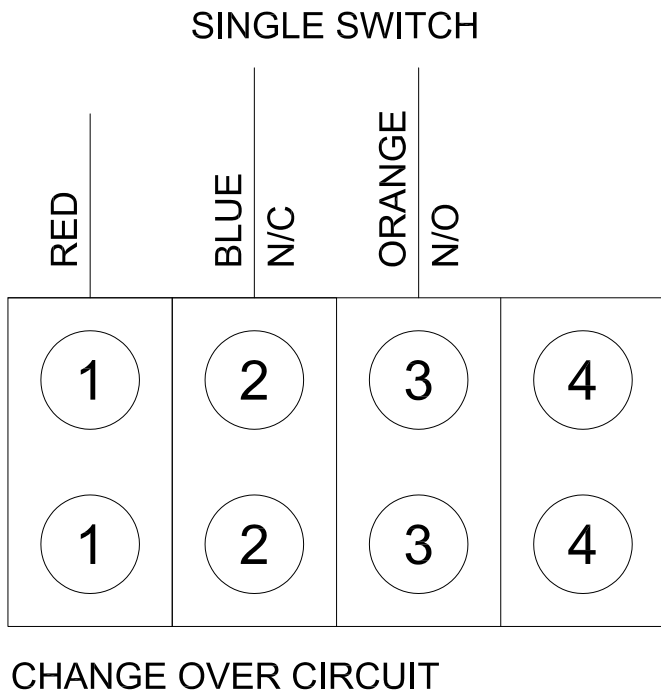

# Electrical Connections

## 5.4 Earthing

The ATEX Group I Float switch has 2 earthing points, the internal earth point is provided in the float switch lid, while the second earthing point is external to the float switch on the body.

Both earthing points have an earthing tag secured in place with a Stainless Steel M6 socket headed bolt and spring washer.

All switches should be earthed correctly to maintain the ATEX certification.

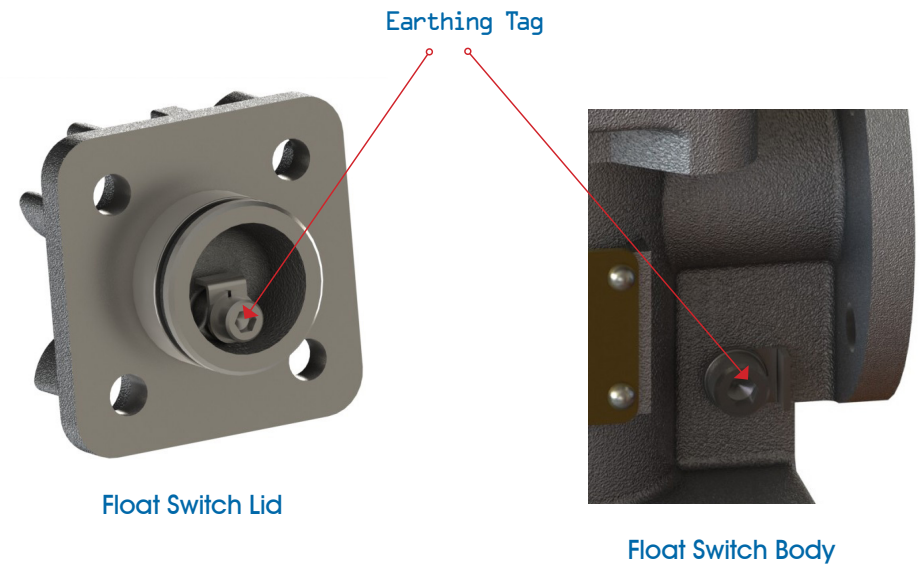

## 6. Commissioning / Functional Testing

---

### Functional Testing

Before the float switch is installed, it can be checked for functionality using a continuity checker or ohmmeter.

- i) Remove the terminal cover lid as described in section 5.2.
- ii) Connect the continuity checker to the wires for the switch (switch configuration as shown in section 5.3).
- iii) Raise the float between the float stops and confirm that the switch changes state.
- iv) Lower the float and confirm that the switch changes state.

### Commissioning

The ATEX Group I float switches can only be tested from the vessel externally or tested with the liquid level rising / falling in the vessel. It is therefore recommended that the ATEX Group I float switch is functional tested before the switch is installed in the vessel.

#### **WARNING:**

*When the FS1353/- is being used in an explosive atmosphere, any supplies to the switch MUST be isolated before removing the float switch lid.*

## 7. Maintenance

---

The ATEX Group I Float switches are designed to give long periods of satisfactory trouble-free life, and under normal conditions, they require little maintenance.

AMS recommend that the ATEX Group I float switches are periodically functional tested every 6 months to confirm operation, if the process medium contains heavy soiling or coarse suspended matter it is recommended to reduce this testing interval, to confirm that the float still has free movement on the guide tube and is not obstructed from operating.

#### **Note:**

*The float switch switching points are fixed and not adjustable.*

If the switch fails to operate, the unit should be returned to AM Sensors along with a completed declaration returns form (this form is available upon request).

The ATEX Group I Float switch may not be modified without written permission as this would invalidate approvals and warranty.

## 8. Technical Specifications

---

### RS13 Reed Switch

Switching Action	SPDT (Change over option)
Switching Voltage	400 V AC/DC
Switching Current	1.0 A Max
Max. Power: 60 Watt	60 Watt

## EC Declaration

---



AM Sensors Ltd,  
Chedzoy Lane, Chedzoy,  
Bridgwater, Somerset  
TA7 8QS

† +44 (0)1278 444 650

f +44 (0)1278 434 449

e [info@amsensors.com](mailto:info@amsensors.com)

[www.amsensors.com](http://www.amsensors.com)

AMS reserve the right to make technical changes or modify the contents of this document without prior notice. With regard to purchase orders, the agreed particulars shall prevail.

AMS does not accept any responsibility whatsoever for potential errors or possible lack of information in this document.

AMS reserve all rights in this document and in the subject matter and illustrations contained therein. Any reproduction, disclosure to third parties or utilization of its contents - in whole or in parts - is forbidden without prior written consent of AMS.