



INSTALLATION, OPERATING
& MAINTENANCE MANUAL

DISPLACER FLOAT SWITCHES

TYPE: DS11, DS12, DS21 & DS22

Contents

1. Safety Information	1
2. Functional Description	2
3. Area of Application	3
4. Installation	4
5. Electrical Connections	6
6. Commissioning / Functional Testing	13
7. Maintenance	16
8. Technical Specifications	17

WARNING:

Failure to comply with the instructions described within this manual can lead to malfunction or damage to the switch and if the switch is incorrectly installed the ATEX certification may be void.

1. Safety Instructions

Read these instructions before installing the DS11 / DS21 / DS22 Displacer float switches and placing them into operational service.

These instructions are intended for the personnel responsible for the installation and commissioning of the float switch.

Comply with the relevant safety regulations when using the equipment.

Do not install the float switch in the immediate vicinity of any strong electromagnetic fields (recommended min distance >1 meter).

Do not subject the float switch to heavy mechanical loads.

2. Functional Description

AMS magnetic float switches are ideal for high and low liquid level alarm, and pump control duties. These Liquids should not contain heavy soiling or coarse suspended matter and must not show a tendency to crystallize when drying out. If the liquids that the float switch is being used to measure do have conditions as listed above then routine maintenance should be carried out to ensure the float has free movement on the guide tube.

The Vertical float switch are designed to open or close a circuit ("switch") as a changing liquid level within a vessel passes the level of the float (the Switch Point).

When the process liquid level is below the Switch Point, the contacts are either open circuit (NO) or closed circuit (NC) depending on the switch configuration as determined by the customer, when the liquid level raises the float will become buoyant and as the liquid level increases passed the switch point the contacts will change over.

The floats have an in- built magnetic which operates the reed switch contact through the wall of the guide tube. Thus the switching operation is without direct contact to the liquid, free of wear and tear, and does not require any power supply.

Benefits of using AMS Magnetic Float Switch Technology

- i) Over 40 years of experience - a proven design (Ex Alan Cobham)
- ii) Simple, reliable, and cost effective level measurement technology
- iii) Tough, rugged design for long life in aggressive environments
- iv) Operates in almost any liquid at high pressures and temperatures
- v) Measurement is unaffected by changes in process temperature, dielectric, or the presence of vapours

3. Areas of Application

3.1 DS11 / DS12 Weatherproof Displacer Float Switches

The DS11 and DS12 Displacer series float switch are IP65 rated and designed to be installed in any areas either internally or externally to a building, apart from areas that are designated as an ATEX Hazardous area.



3.2 DS21 / DS22 Flameproof Displacer Float Switches

An approval has been issued for the DS21 / DS22 Displacer float switches for use as explosion-protected equipment within the scope of application defined by EU Guideline 94/9/EC ATEX in hazardous areas.

They comply with the specifications concerning equipment and protective systems intended for use in potentially explosive atmospheres.

THE TECHNICAL DATA IN THIS OPERATING INSTRUCTION MUST BE COMPLIED WITH.

DS21 / DS22 Displacer Float Switches carry the following ATEX Certification plate:

⊕ AM SENSORS LTD	FLAMEPROOF SWITCH	⊕
+44 (0) 1278 444650	www.amsensors.com	
Max.Liq.& amb.temp. 70°C T6	 II 2/1 G Exd IIC T Gb	
85°C T5	Ser.No:	
Yr of Manuf. 120°C T4	Max.rating:	
150°C T3	ATEX Certificate no:	
⊕	 0359 ITS 14 ATEX 17989	⊕

4. Installation

4.1 Removal of transport packaging

Remove the float switch carefully from the transport packaging; never forcibly remove the float switch from the packaging.

Always handle the float switch by the switch body, gently supporting the float suspension wire.

Do not lift the float switch up by the float or suspension wire as this could cause damage to the float switch and invalidate any warranty.

Cut the temporary ties on the coil of the suspension wire do not allow kinks to form in the suspension wire.

4.2 Installation

The Displacer float switch series are designed to be solely installed in the vertical position, do not attempt to install this switch design in the horizontal position as the switch will not operate.

Lower the float into the vessel using the suspension wire; once the suspension wire has been fed into the vessel gently lower the switch body onto the switch mounting points (ensure that the gasket supplied is fitted to the switch body before installing the float).

Do Not Drop the Float and suspension wire directly into the tank as this can cause the switch to be damaged.

Prior to installing the float switches confirm that the vessel has the correct mounting arrangement for the float switch. The standard mounting arrangement is indicated in Fig 1, with adaptor flanges and screwed process connections options available.

Installation

Fig 1.

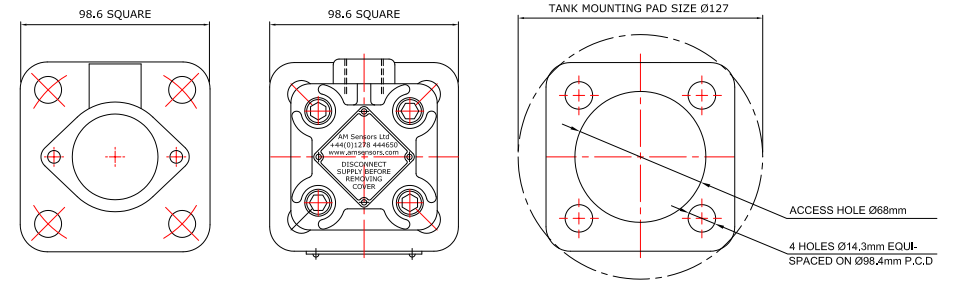

For ease of any future maintenance and removal of the float switches with the standard mounting option, we recommend that that 4 off M14 studs are used installed on a PCD of Ø98.4mm.

Assemble the float switch to the vessel using suitable bolts and washers; tighten the float switch mounting nuts to the specific torque rating for the studs and bolts.

5. Electrical Connections

5.1 DS21 & DS22 FLAMEPROOF VERSIONS

WARNING:

It is essential that the electrical supply to the switch does not exceed the electrical rating of the reed switch and that loads in excess of the maximum reed switch operation are not applied.

Ensure the switch is not operated outside its designated temperature range (see label).

Install an M20 ATEX Ex 'd' rated cable gland to the cable entry (Item 4) of the float switch; ensure that the manufactures instructions are strictly followed.

Undo the 4 off M10 socket headed screws and spring washers (Item 1), and while holding the float switch body, carefully lift the lid (Item 2) in an linear direction (gently rotating clockwise and anti-clockwise aids removal of the lid).

Remove the terminals and terminal base (Item 3) in an upwards direction, being careful not to put any strain on the switch wiring.

Once the switches have been terminated to the system, gently insert the terminals and terminal base (Item 3) back into the float switch body; replace the lid (Item 2) onto the body making sure that the O-ring is not trapped.

Replace and tighten the 4 off M10 socket headed screws (Item 1), to no greater than 10 Lbs torque.

Electrical Connections

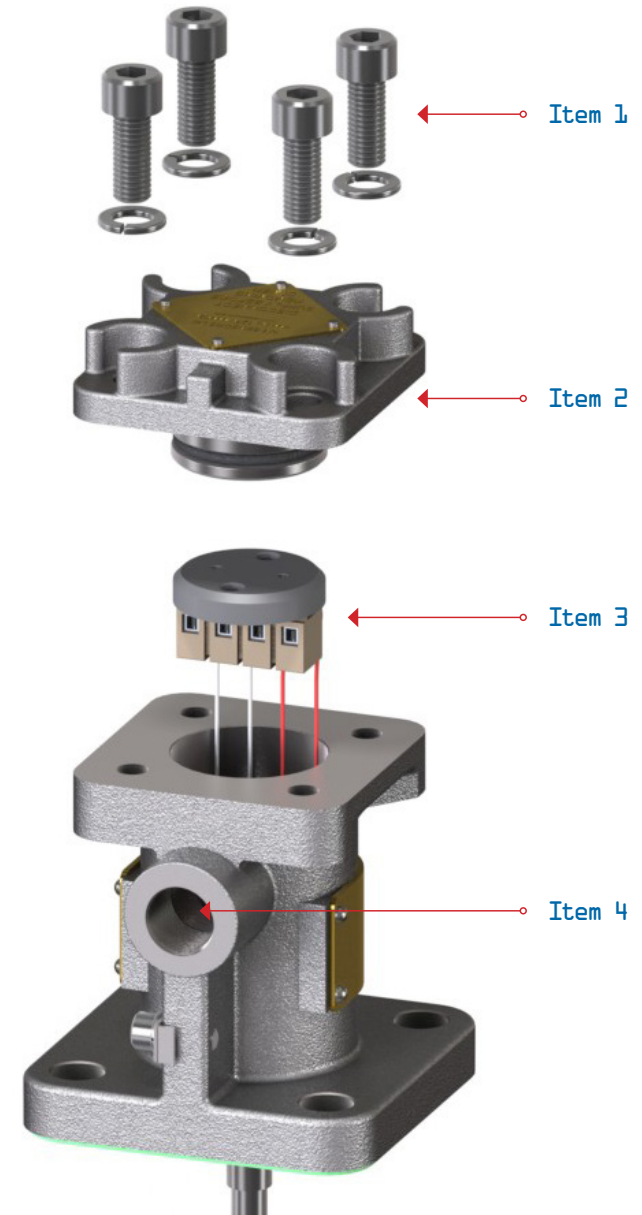

Electrical Connections

5.1 DS11 & DS12 Weatherproof Version

Warning: It is essential that the electrical supply to the switch does not exceed the electrical rating of the reed switch and that loads in excess of the maximum reed switch operation are not applied.

Install an M20 cable gland to the cable entry (Item 4) of the float switch; ensure that the manufactures instructions are followed.

Undo the 2 off M6 socket headed screws (Item 1), lift the lid (Item 2) in an upwards direction to gain access to the terminals.

Care should be taken when removing the lid, not to lose the gasket (item 3).

Once the switches have been terminated to the system, replace the lid (Item 2) onto the body making sure that the gasket (item 3) is installed correctly to maintain the IP rating.

Replace and tighten the 2 off M6 socket headed screws to no greater than 10 Lbs. torque

Electrical Connections

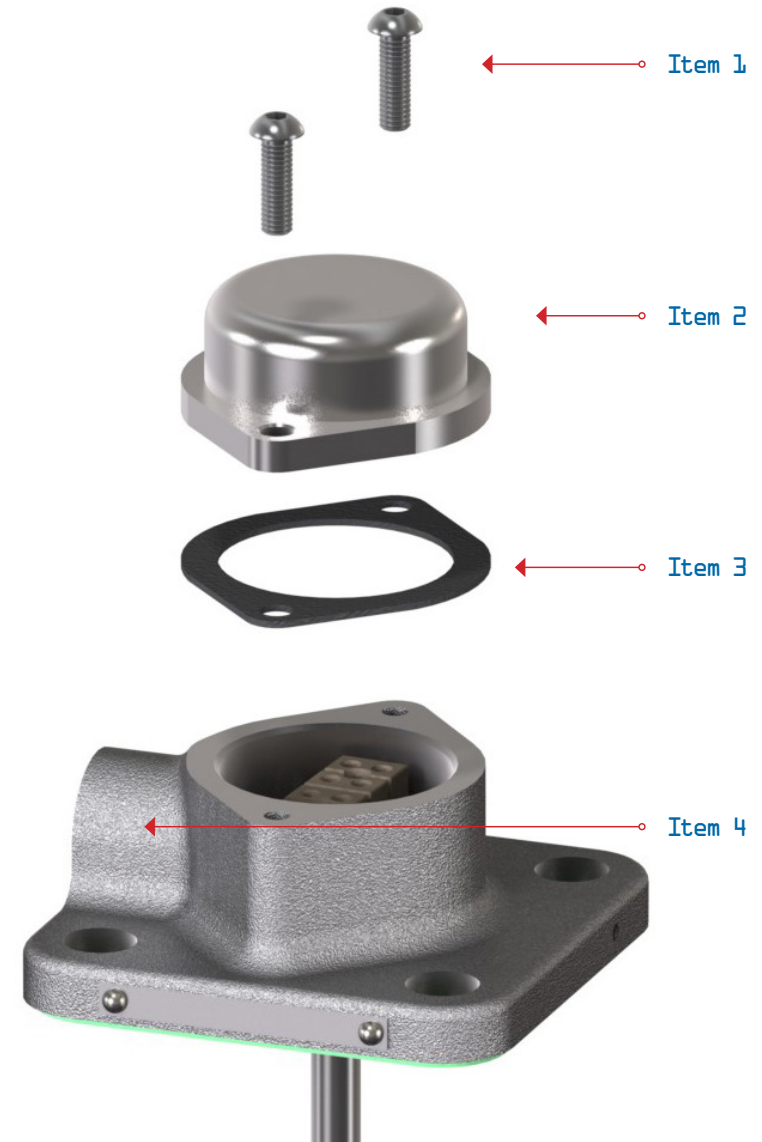

Electrical Connections

5.3 Switch Wiring Configuration

Single pole / single throw switches are terminated using two wires per switch, these wires have the following colours:

(Single) Upper level switch White Wires

The switch wires are terminated to a four way terminal block in the following configuration:

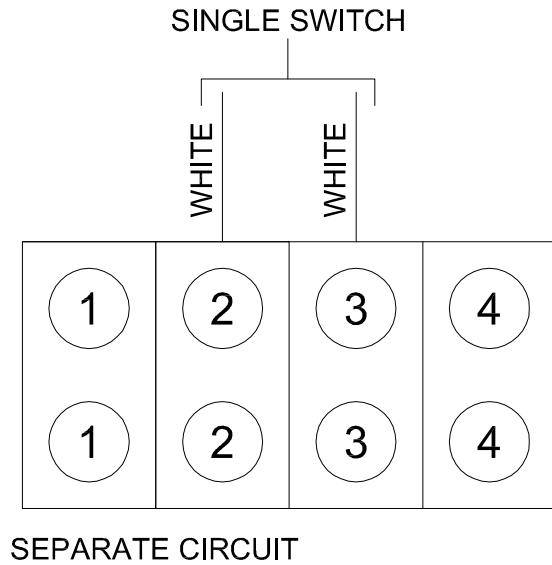

Electrical Connections

Single pole / double throw switches are terminated using 3 wires; these wires have the following colours and configuration:

Single Switch

Normally closed (N/C) contact	White Wire
Normally open (N/O) contact	Red Wire
Common contact	Black Wire

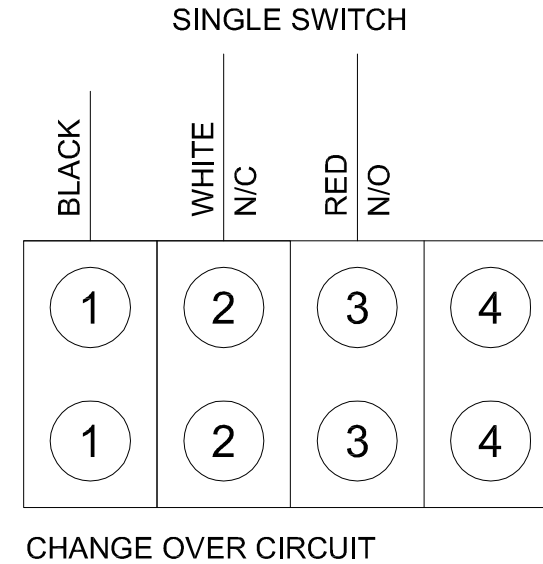

Electrical Connections

5.4 Earthing Flameproof Versions

The Flameproof Float switch has 2 earthing points, the internal earth point is provided in the float switch lid, while the second earthing point is external to the float switch on the body.

Both earthing points have an earthing tag secured in place with a Stainless Steel M6 socket headed bolt and spring washer.

All switches should be earthed correctly to maintain the ATEX certification.

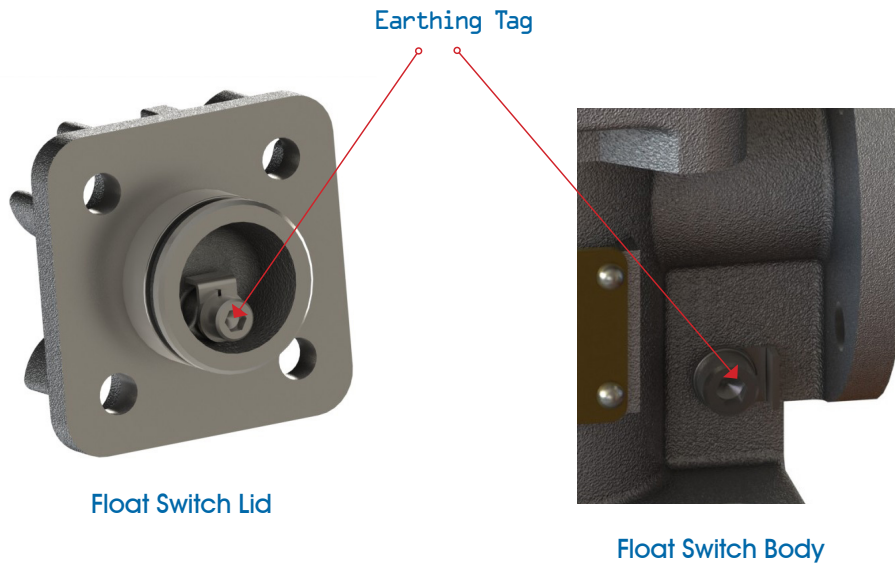

6. Commissioning / Functional Testing

Functional Testing - DS11, DS12, DS21 & DS22

Before the float switch is installed, it can be checked for functionality using a continuity checker or ohmmeter.

- i) Remove the terminal cover lid as described in section 5.1 / 5.2.
- ii) Connect the continuity checker to the wires for the switch (switch configuration as shown in section 5.3).
- iii) Gently apply tension to the suspension wire by holding the switch body vertical and allowing the displacer float to apply the tension to the suspension wire, this will set the switch contacts in the normal operating state.
- iv) Gently release the tension on the suspension wire by raising the displacer float and confirm that the switch has changed state.
- v) Allow the displacer float to tension the suspension wire and confirm that the switch has returned to its normal operating state.

Commissioning / Functional Testing

Commissioning

The DS11 or DS21 – Non-Checkable type Displacer float switches can only be tested from the vessel internally or tested with the liquid level rising / falling in the vessel. It is therefore recommended that the DS11 or DS21 type Displacer float switch is functional tested before the switch is installed in the vessel.

The DS12 & DS22 – Checkable type Displacer float switch have an in-built checkable function and this type of switch can be tested after installation or as part of a routine maintenance plan.

- i) Remove the padlock from the test handle.
- ii) Pull the test handle in a vertical direction.
- iii) With the test handle pulled, confirm on the system that the switch is connected to responds in the correct manner.
- iv) Push the test handle in a vertical direction firmly until it has seated.
- v) Apply the padlock to the test handle.

WARNING:

The padlock must be refitted after every functional test.

When the DS21 or DS22 is being used in an explosive atmosphere, any supplies to the switch MUST be isolated before removing the float switch lid.

Note:

If the liquid level within the vessel is greater than the switching set point, testing the switch using the test handle will not have any effect on the switch as the float will already be raised and the switch contact made.

7. Maintenance

The displacer switches are designed to give long periods of satisfactory trouble-free life, and under normal conditions, they require little maintenance. Only technically competent personnel should repair or maintain the product and only spares supplied from AM Sensors Ltd are to be used. Products may not be modified without written permission as this would invalidate approvals and warranty.

The displacer float is adjustable on the suspension wire to compensate for individual switching levels.

Adjusting the Switching level:

- i) Undo the M4 screw on the nipple underneath the displacer float.
- ii) Slide the displacer float up the suspension wire until the centre of the displacer float is level with the required switching level.
- iii) Slide nipple up the suspension wire until it touches the underside of the float and retighten the M4 screw to 10lbs torque.
- iv) Leave any excess wire trailing from the displacer float and if applicable coil the wire up (depending on the length of excess wire).

Note:

Do not trim the excess suspension wire as the weight of the float and wire has been calculated for the Specific Gravity (S.G) of the fluid. Trimming the excess wire will result in an inaccurate switching level.

AMS recommend that the DS11, DS12, DS21 and DS22 Displacer float switches are periodically functional tested every 6 months to confirm operation, if the process medium contains heavy soiling or coarse suspended matter it is recommended to reduce this testing interval, to confirm that the float is not obstructed from operating the switch.

If the switch fails to operate, the unit should be returned to AM Sensors along with a completed declaration returns form (this form is available upon request).

8. Technical Specifications

RS7 Reed Switch

Switching Action	SPST (NO or NC contacts depending on configuration).
Switching Voltage	250 V AC/DC
Switching Current	5.0 A Max
Max. Power	250 Watt

RS13 Reed Switch

Switching Action	SPDT (Change over option)
Switching Voltage	400 V AC/DC
Switching Current	1.0 A Max
Max. Power	60 Watt

AM Sensors Ltd,
Chedzoy Lane, Chedzoy,
Bridgwater, Somerset
TA7 8QS

† +44 (0)1278 444 650

f +44 (0)1278 434 449

e info@amsensors.com

www.amsensors.com

AMS reserve the right to make technical changes or modify the contents of this document without prior notice. With regard to purchase orders, the agreed particulars shall prevail.

AMS does not accept any responsibility whatsoever for potential errors or possible lack of information in this document.

AMS reserve all rights in this document and in the subject matter and illustrations contained therein. Any reproduction, disclosure to third parties or utilization of its contents - in whole or in parts - is forbidden without prior written consent of AMS.