



SPECIFICATION // DATA SHEET

ENGINEERED VERTICAL FLOAT SWITCHES FS1 & FS2 SERIES

Introduction

Quality & Experience

AMS have retained the personnel who have produced the flameproof float switches for over 40 years to ensure that the world renowned quality that is maintained.

With a robust build quality and mechanical operation, our ranges of float switches have a proved track record within many industries such as; Petro-Chem, Chemical, Power Stations, Utilities.

Flexible Specifications

Components are stocked in various different states of assembly to reduce manufacturing lead times; and each float switch is manufactured to individual customer specifications to suit their process applications.

If the standard specification shown does not meet your application requirements please call our AMS Sales Team who will be happy to discuss your requirements and provide a solution, as AMS can produce custom float switches to suit your needs.

Application Areas

For use with tank level applications, the vertical float switch series can be used for "Liquid Level Alarms", "Pump Control" and "Valves Control" when filling, emptying or interface control between two liquids.

The Vertical Float Switch series are divided into two classes, one class for the Flameproof ATEX Certified float switch and the other class a weatherproof IP65 float switch.

FS11 / FS12 Weatherproof Vertical Float Switches

The FS11 and FS12 Vertical series float switch are IP65 rated and designed to be installed in any areas either internally or externally to a building, apart from areas that are designated as an ATEX Hazardous area.

FS21/FS22 Flameproof Vertical Float Switches

An approval has been issued for the FS21 / FS22 Vertical float switches for use as explosion-protected equipment within the scope of application defined by EU Guideline 94/9/EC ATEX in hazardous areas.

They comply with the specifications concerning equipment and protective systems intended for use in potentially explosive atmospheres.

ATEX Certified to II 2 G / EEx'd' IIC T6-T3

AMS can offer the FS11 or FS21 in a side up or side down version which is suitable for applications where the vessel has side mounted flanges and a switching point which higher or lower than the mounting flange.

Supplied into the industry for over 40 years by Alan Cobham and world renowned for quality, the Vertical float switch series are now owned and manufactured in the UK by AM Sensors Ltd.

FS21 & FS22 Flameproof Version Specification

ATEX Rating	EEx 'd' II 2 /1 G T3 to T6 (Std)
Temperature	-40 to +150 °C
Material	Body / Flange: 316 Stainless Steel // Wetted Parts: 316 Stainless Steel
Pressure	With Spherical Float Upto 40 Bar (580 Psi) // With Cylindrical Float up to 10 Bar (145 Psi)
IP Rating	IP65
S.G Range	≥0.6 (600kg/m ³)
Cable Entry	Single M20 x 1.5 (Other options available)
Switch Lengths	1st switching position up to 3m with reinforcing tube // Sub sequential switching position up to 2m

FS11 & FS12 Weatherproof

Temperature	-40 to +150 °C
Material	Body / Flange: 316 Stainless Steel // Wetted Parts: 316 Stainless Steel
Pressure	With Spherical Float Upto 40 Bar (580 Psi) // With Cylindrical Float up to 10 Bar (145 Psi)
IP Rating	IP65
S.G Range	≥0.6 (600kg/m ³)
Cable Entry	Single M20 x 1.5 (Other options available)
Switch Lengths	1st switching position up to 3m with reinforcing tube // Sub sequential switching position up to 2m

Switch Specifications

	Type A	Type B
Action	SPST	SPCO
Contact material	Rhodium	Rhodium
Switching Capacity	250W	60W
Switching Voltage	250V AC/DC	400V AC/DC
Switch Current	5 A	1 A
Contact Resistance	100 mΩ	100 mΩ□
Bounce Time	1.0 ms	0.5 ms
Release Time	0.2 ms	0.15 ms
Operating Temperature	-40 to 150°C	-40 to 125°C

FS12 & FS22 Checkable Design Functions

AMS can offer 3 different designs of checkable functions:

Design	Operation	Typical Applications
Design 1	Spherical Float with cage: When the test handle is operated the cage and float are lifted in an upwards direction changing the state of the contacts.	For use when the liquid level is below the floats i.e. High / High High Level alarms.
Design 2	Cylindrical Float: When the test handle is operated the float is pushed in a downwards direction changing the state of the contacts.	For use when the float is submersed in liquid but requires periodic functional testing, i.e Low / Low Low Level Alarms.
Design 3	Spherical Float with cage & Cylindrical Float: When the test handle is operated the cage and float is lifted in an upwards direction while the Cylindrical Float is pushed in a downwards direction.	For use on a dual High & Low alarm circuit which utilises a single float switch to generate the alarms.

Standard Flange Dimensions

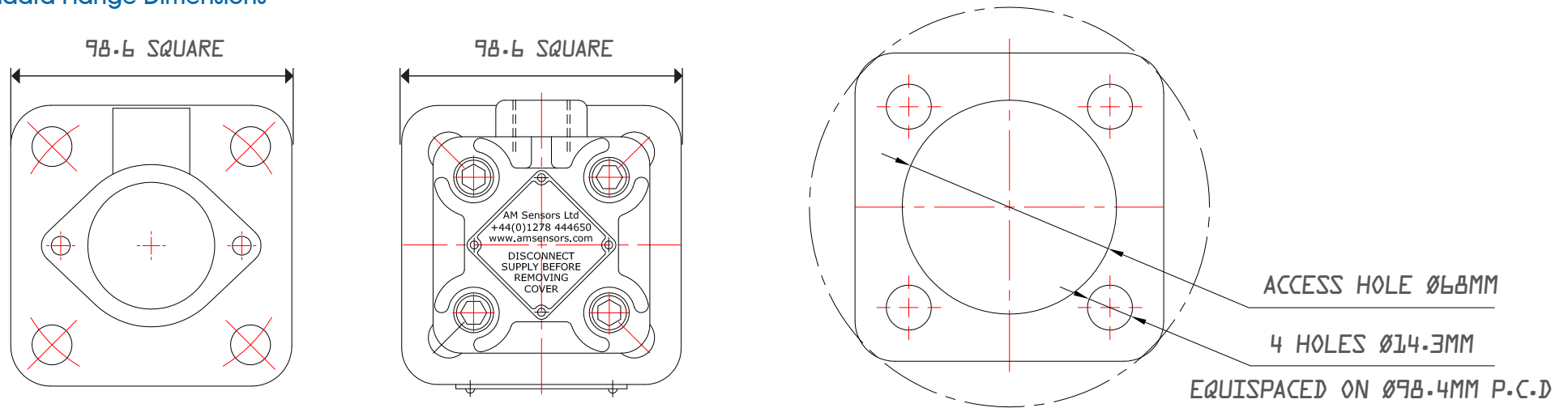

NOTE: Further mounting options are available including screwed, adaptor flanges and standard flanges with different drilling dimensions i.e. Ø96 mm P.C.D.

Top Mounted Vertical Float Switch

Connections to conform to: BS EN 60079-14: 2008

The illustration shows a FS22 series dual level checkable float switch configuration.

Generally the maximum recommended number of floats that can be installed on a FS12 or FS22 checkable float switch is set to two; a FS11 or FS21 non-checkable is used for 3 and 4 level switching.

Other configurations are available to special order on request.

For Tri-Level switching use Dimension 'C' for the 3rd switching point.

For Quad-Level switching use Dimension 'D' for the 4th switching point.

All measurements are taken from the mounting flange face to the desired switching level.

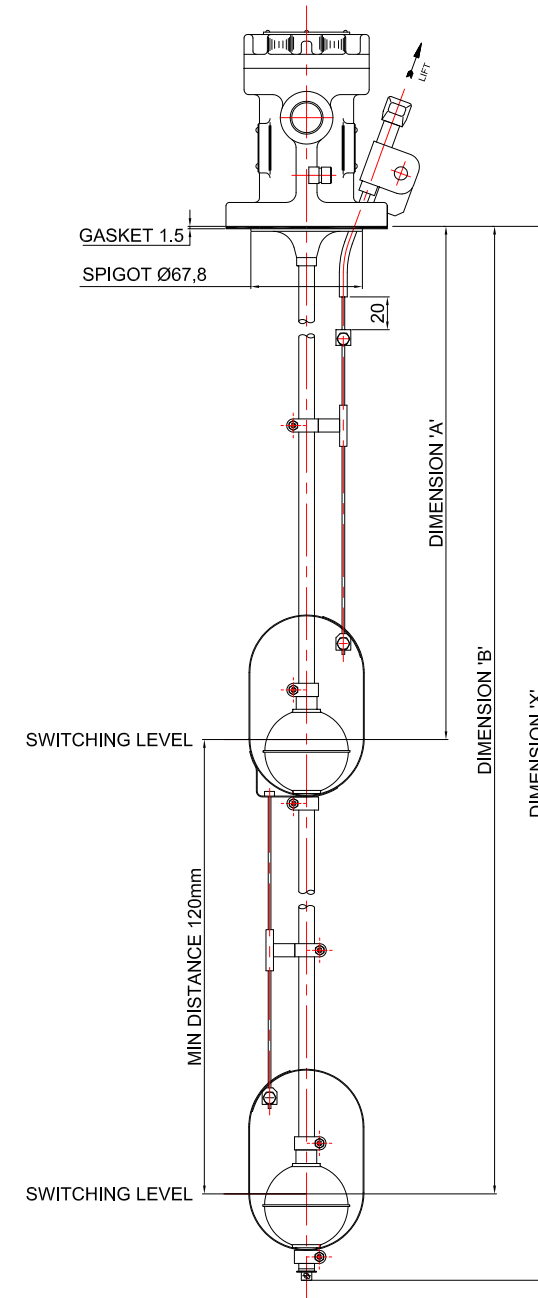

Side Up / Down Vertical Float Switch

Connections to conform to: BS EN 60079-14: 2008

The illustration has shown only a single level switching point, but upto four switching points can be offered.

Please use Dimensions B, C & D for the other switching points.

Other configurations are available to special order on request.

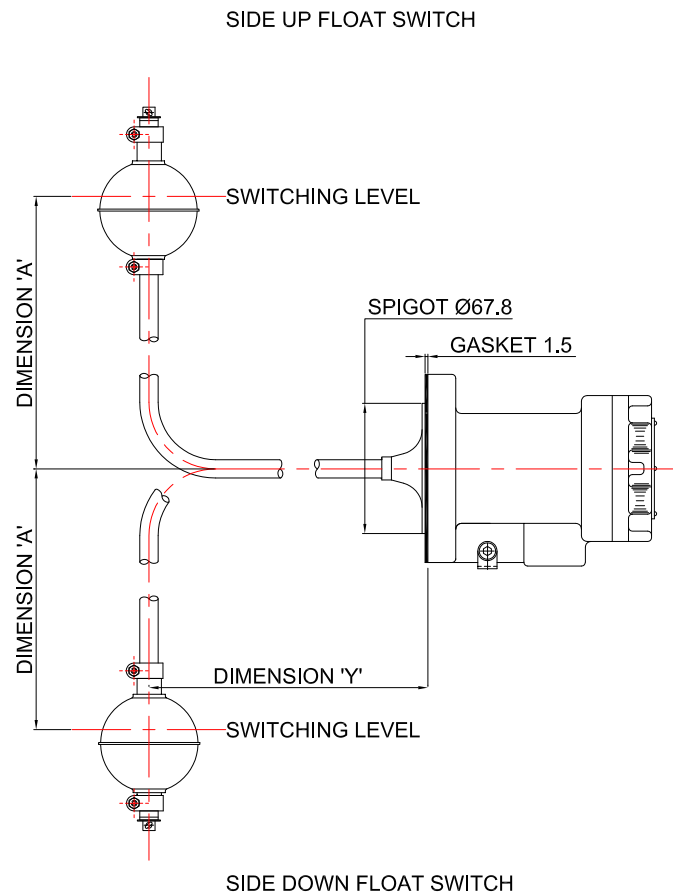

Terminal Details

For wiring details please see the installation, operating and maintenance manual supplied with the float switch.

Vertical Float Switch available Switching Actions

- MOR – Make on Rise
- BOR – Break on Rise
- COR – Change on Rise (Type B Switch Only)
- MOF – Make on Fall
- BOF – Break on Fall
- COF – Change on Fall (Type B Switch Only)

Ordering Information

When ordering float switches, technical information is required to ensure the customer is supplied with the correct product for the process conditions.

Please complete our float switch questionnaire and email to sales@amsensors.com or contact our sales team on +44 (0)1278 444650

Vertical Float Switch Questionnaire

Part Number								Description
FS								Engineered Float Switch

1	Weatherproof
2	Flameproof

1	Non-Checkable
2	Checkable

1	Top Mounted
2	Side Up (Non Checkable, Max 2 Switch Points)
3	Side Down (Non Checkable, Max 2 Switch Points)

1	One Switch Point
2	Two Switch Points
3	Three Switch Points
4	Four Switch Points
5	Five Switch Points

A	250W SPST, Switch Rating
C	60W SPDT, Switch Rating

NOTE: For different switch ratings on multi level switches enter the digit in switch position order i.e. AC or AAC

1	Stainless Steel Float - Standard
5	One Interface Float - St/St
6	Two Interface Float - St/St

1	upto 300mm Total Length
2	upto 600mm Total Length
3	upto 900mm Total Length
4	upto 1200mm Total Length
5	upto 1500mm Total Length
6	upto 2000mm Total Length
7	upto 3000mm Total Length
X	Special

NOTE: Total Length is a minimum of 75mm past the final switch point

	No Support Tube
1	upto 1000mm Support Tube
2	Upto 2000mm Support Tube
3	Upto 3000mm Support Tube

NOTE: Support tube is only available upto the first switch point

TOTAL COST

OPTIONS:

FS1415/17	3" ASA 150 St/St Adaptor Flange
FS1415/18	4" ASA 150 St/St Adaptor Flange
FS1415/19	6" ASA 150 St/St Adaptor Flange
FS1415/20	8" ASA 150 St/St Adaptor Flange
COFC	Certificate of Conformity
MATC	Material Certificate
WELD	Weld Procedures
CALC	Calibration Certificate
PRESC	Pressure Test Certificate

SPARES:

X3325	Gasket
-------	--------

CALL FOR PRICING CUSTOMER SPECIFIC APPLICATIONS REQUIREMENTS

Chambers

Chamber mounting

In situations where mounting of the float switch in an external chamber is required, AMS have in house welders coded to ASME IX and European standards to provide a complete assembly with pressure testing, painting and NDT testing to each customer's specific requirements.

» **Material Origins:**

The origin of the materials used in the construction can be sourced as European, Worldwide or to meet EN 10204-3.1 Material specification.

» **Nace Construction:**

AMS Chambers can be constructed to meet NACE MR 0175 / ISO 15156 for sour service applications.

» **Chamber Design:**

AMS Chambers are designed to meet the ASME B31.3 - Process Piping Codes.

» **Pressure Equipment Directive:**

AMS Chambers are designed to meet the European Pressure Directive (PED) 97/23/EC Guidelines.

» **ISO Approved:**

AMS Chambers are manufactured by ISO approved company for QA, Environment and OHSAS.

» **Process Connections:**

AMS Supply chambers with a wide range of process connections to meet ASME/ANSI B16.5 and EN1092-1.

» **Coded Welders:**

Welders are certified to ASME Boiler and Pressure Vessel Code Section IX and ISO9606-1.

» **Optional Weld Inspection:**

X-Ray for full penetration butt welds.

Magnetic particle for Carbon Steel Chambers.

Dye Penetrant Inspection of branch welds (all chambers).

» **Hydrostatic Testing (Optional):**

The Chambers can be hydrostatically tested to meet the ASME B31.3 Process Piping Code (1.5 X Design Pressure @ ambient temperatures).

» **Painting (Optional):**

The chambers can be painted to meet individual customer specifications, including offshore environments.

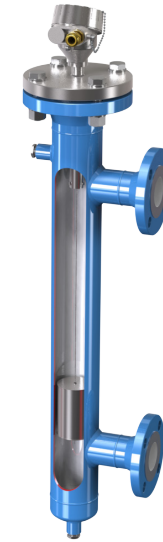

CHAMBER WITH DISPLACER SS

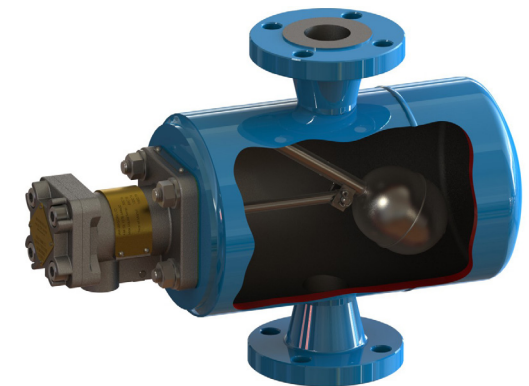

CHAMBER CUT THRU PAINTED
CARBON STEEL

Documentation and Testing

AMS can produce a full documentation package to support the chamber products. A data book containing the documents required by each customer is produced and shipped with each chamber. Documents available include (not restricted to!):

- » Welder Qualification Certs
- » Weld Procedure Qualifications
- » Weld Procedure Specifications
- » GA Drawings
- » Pressure Test Certificates
- » Certificate of Conformity to NACE and PED
- » QA Plan
- » Welder and NDT Inspection Records
- » X-ray, Dye Pen and PMI Tests
- » Instrument Tag Lists
- » Instrument Data Sheets
- » Material Certificates

In addition to the above AMS can also provide:

- » **Accessories:**

AMS offer a range of accessories for use in conjunction with the chambers such as valves, gaskets, nuts / bolts and fittings.

- » **Instrumentation:**

AMS offer a wide range of process instrumentation, including various level measurement technologies, which when used in conjunction with our chambers provide complete level measurement solutions for any application.



AM Sensors Ltd,
Chedzoy Lane, Chedzoy,
Bridgwater, Somerset
TA7 8QS

† +44 (0)1278 444 650
f +44 (0)1278 434 449
e info@amsensors.com
www.amsensors.com

AM SENSORS LTD (AMS) RESERVE THE RIGHT TO MAKE TECHNICAL CHANGES OR MODIFY THE CONTENTS OF THIS DOCUMENT WITHOUT PRIOR NOTICE.
AMS DOES NOT ACCEPT ANY RESPONSIBILITY WHATSOEVER FOR POTENTIAL ERRORS OR POSSIBLE LACK OF INFORMATION IN THIS DOCUMENT.
AMS RESERVE ALL RIGHTS IN THIS DOCUMENT AND IN THE SUBJECT MATTER AND ILLUSTRATIONS CONTAINED THEREIN.
ANY REPRODUCTION, DISCLOSURE TO THIRD PARTIES OR UTILIZATION OF ITS CONTENTS - IN WHOLE OR IN PARTS – IS FORBIDDEN WITHOUT PRIOR WRITTEN CONSENT OF AMS.